

GRU AUTOMONTANTI IDRAULICHE  
SELF ERECTING CRANES  
GRUES MONTAGE RAPIDE  
SELBSTMONTIERENDE HYDRAULIKKRÄNE  
КРАНЫ ГИДРАВЛИЧЕСКИЕ САМОМОНТИРУЮЩИЕСЯ

CE   
H1B3-DIN15018  
CRANES AND TOOLS **VICARIO**





**CONFIGURAZIONE - REAZIONI - HR36**

CONFIGURATION - REACTIONS / CONFIGURATION - RÉACTIONS / KONFIGURAZION – REAKTIONEN /  
 КОНФИГУРАЦИЯ КРАНА

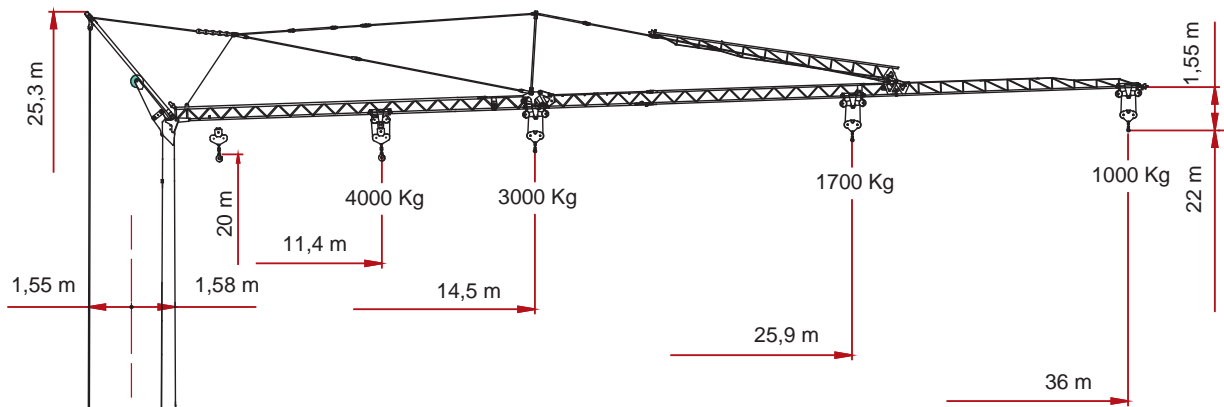
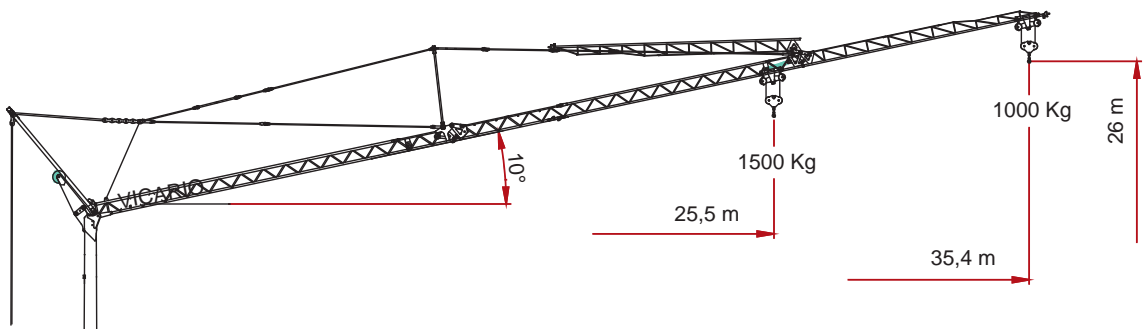
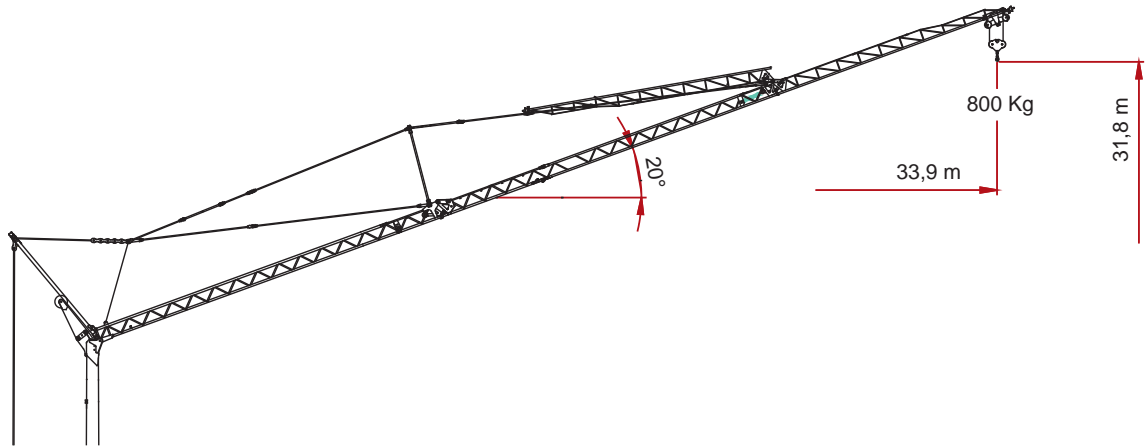

kg	3000	2670	2320	2046	1825	1644	1493	1364	1254	1158	1074	1000
----	------	------	------	------	------	------	------	------	------	------	------	------

m	14.5	16	18	20	22	24	26	28	30	32	34	36
---	------	----	----	----	----	----	----	----	----	----	----	----

kg	4000	3776	3134	2670	2320	2046	1825	1644	1493	1364	1254	1158	1074	1000
----	------	------	------	------	------	------	------	------	------	------	------	------	------	------

m	11.4	12	14	16	18	20	22	24	26	28	30	32	34	36
---	------	----	----	----	----	----	----	----	----	----	----	----	----	----



## CARATTERISTICHE AZIONAMENTI PRINCIPALI

MAIN DRIVE CHARACTERISTICS / CARACTÉRISTIQUES ACTIONNEMENTS PRINCIPAUX / HAUPTBEDIENUNGSEIGENSCHAFTEN / ХАРАКТЕРИСТИКА ГЛАВНЫХ ПРИВОДОВ

 400 V (+10% - 10%) 50 Hz 12 kVA

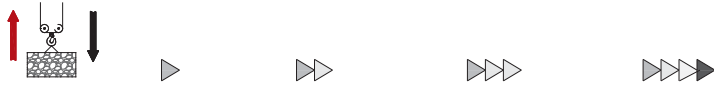

m/l'	8	20	46	56
kg	3000	3000	1200	800
kW	11 (Inverter)			



m/l'	8 - 4	20 - 10	46 - 23	56 - 28
kg	2000 - 4000	2000 - 4000	1200 - 2400	800 - 1600
kW	11 (Inverter)			

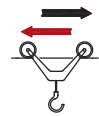

g/l'	16	26	48.7 (↗ 35.7)
kW	3 (Inverter)		

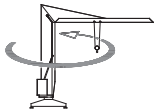

m/l'	0.17	0.43	0.85
kW	3 (Inverter)		

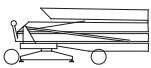

15.500 Kg.



8.000 Kg. + 16.900 Kg.

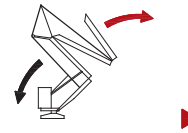
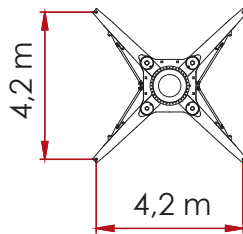

min	18
kW	3

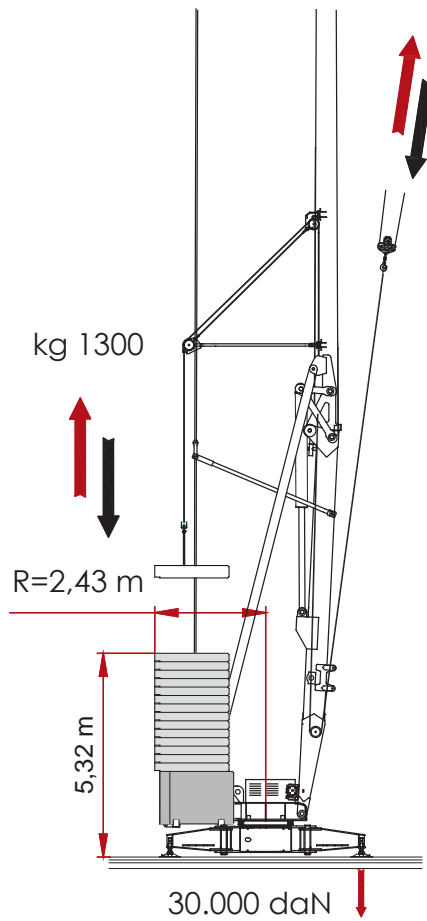

F [daN]

SFORZI MASSIMI  
AL PIEDE

MAX STRESSES  
AT THE FOOT

EFFORTS MAX.  
AU PIED

MAX. BEANSPRU  
CHUNG AM FUSS

МАКС. УСИЛИЯ НА  
ПОДНОЖИЕ



**RAMONDI CRANES**  
Building Tower Cranes Since 1946

**SEQUENZA DI MONTAGGIO SU 360°**

ERECTION PROCEDURE ON 360° / DÉRULEMENT DE MONTAGE SUR 360° / AUFSTELLVORGANG UBER 360° / ХАРАКТЕРИСТИКА ГЛАВНЫХ ПРИВОДОВ

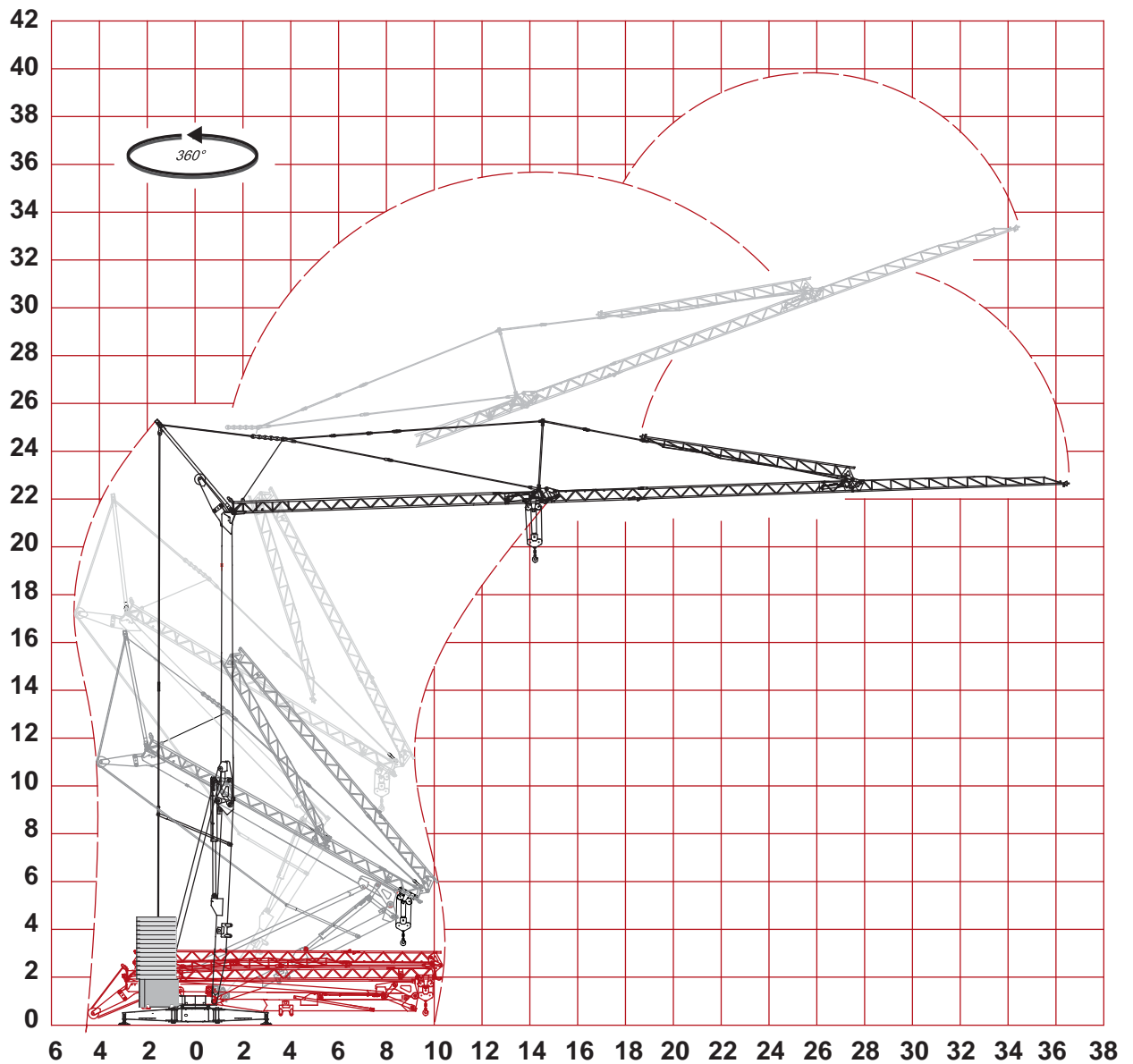

GRU AUTOMONTANTI IDRAULICHE

SELF ERECTING  
CRANESGRUES MONTAGE  
RAPIDESELBSTMONTIRENDE  
HYDRAULIKKRÄNEКРАНЫ ГИДРАВЛИЧЕСКИЕ  
САМОМОНТИРУЮЩИЕСЯ

## SOLUZIONE DI TRAINO

TRACK LOAD PLAN / PLAN DE CHARGEMENT / SCHLEPPLÖSUNG / ВАРИАНТ БУКСИРОВКИ

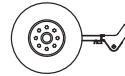
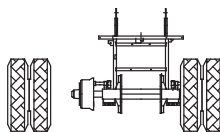
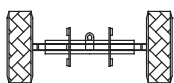
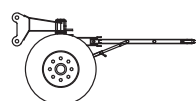
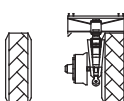
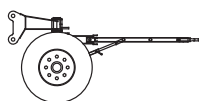
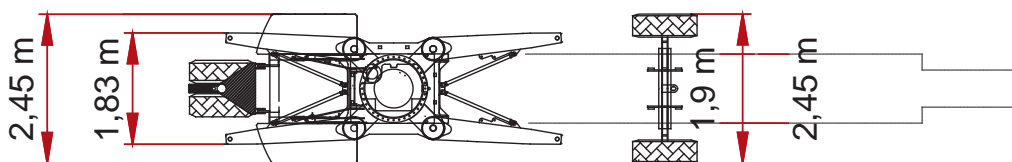
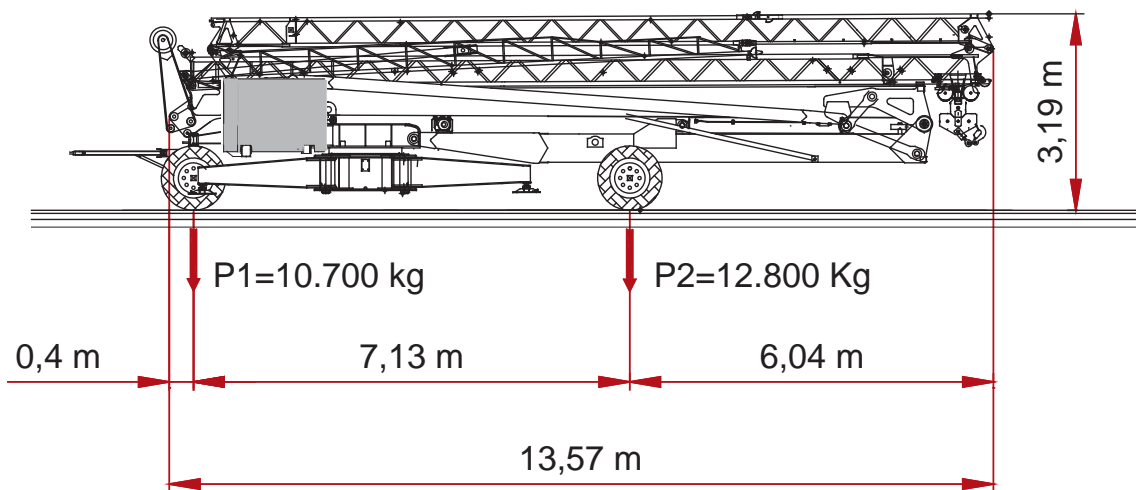

4 x 385-R 22.5

Freni - Brakes - Freins

Bremse - Frenos







## INFO

**RAIMONDICRANES S.p.A.**  
CORSO GARIBALDI n° 253  
20025 LEGNANO [MI] - ITALY



## PROJECT

☎ 0039. 0331.548061  
📠 0039. 0331.450400



## S.A.T.

☎ 0039.0331.548061.258



[www.raimondicranes.com](http://www.raimondicranes.com)  
[info@raimondicranes.com](mailto:info@raimondicranes.com)

HR 36 [ REV. 00.2010 ] ADL / TECHNICAL DEPARTEMENT  
I DATI OGGETTO DELLA PRESENTE SCHEDA POTREBBERO  
SUBIRE MODIFICHE SENZA PREAVVISO

DISTRIBUTORE .DEALER .DISTRIBUTEUR .VERTEILER .ДИЛЕР

---



**RAIMONDI CRANES**  
Building Tower Cranes Since 1946